

SAFL BAFFLE DESIGN GUIDE

**PATENT
PROTECTED**

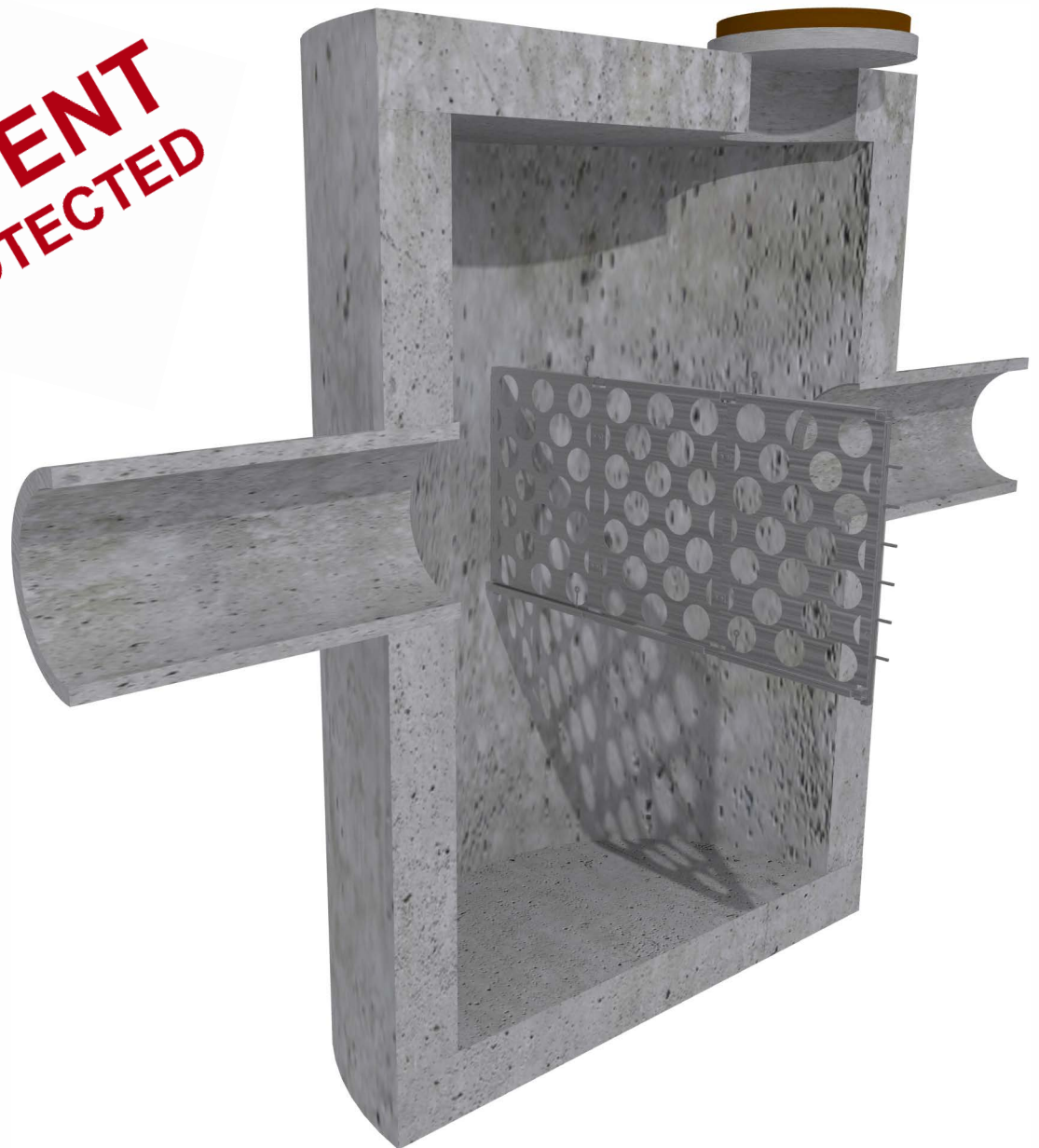

SAFL Baffle is a Patented Device

**PATENT
PROTECTED**

**Manufacture or Reproduction
is strictly forbidden**

Upstream Technologies Patent (SAFL Baffle)

Storm Drain Baffle to Decrease Sediment Washout

U.S. Patent: # 8,715,507 B2
Issued: May 6th, 2014
Expires: May 6th, 2034

Upstream Technologies Patent (SAFL Baffle)

Storm Drain Baffle to Decrease Sediment Washout

Canadian Patent: # 2742207
Issued: September 12th, 2016
Expires: June 7th, 2031

Upstream Technologies Patent (SAFL Baffle)

Flow baffle installation methods and apparatus

U.S. Patent: # 8,663,466 B2
Issued: March 4th, 2014
Expires: March 4th, 2034

Upstream Technologies Patent (SAFL Baffle)

Methods of flow baffle installation

U.S. Patent: # 9,506,237 B2
Issued: November 29th, 2016
Expires: November 29th, 2036

Joint Patent Upstream/Uponor (SAFL Baffle – Europe – Patent Pending)

Storm Drain Baffle to Decrease Sediment Washout

Filed on: 4/22/2016

SKUNK Patent

Garbage Guard Apparatus and Methods of Installation

U.S. Patent # 10,408,242 B1
Issued: September 10, 2019
Expires: February 23, 2038

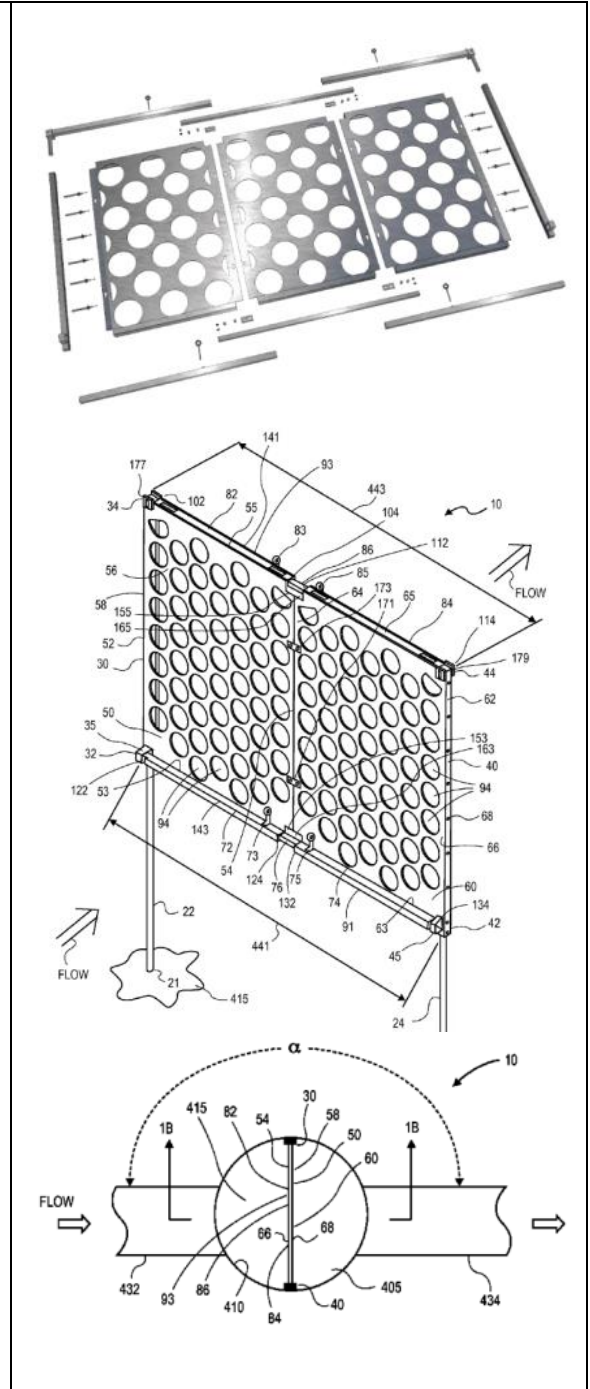

SAFL Baffle DESIGN GUIDE

This guide can be used to design a SAFL Baffle and a sump structure for stormwater sediment removal. It will introduce you to some essential terminology, applications where the SAFL Baffle is useful, and design process. If this guide is not clear, please give our engineering team a call at 651-237-5123.

Contents

- Essential Terminology:..... 2
- Applications: 2
- Conceptual Design Flowchart 3
- Final Design Flowchart..... 4
- Retrofit Criteria Chart 5
- SAFL Baffle Sizing Requirements 6
- SAFL Baffle Bracing Requirements..... 7
- SAFL Baffle Stacking Requirements 8
- Sediment Removal Charts 9
- SHSAM Instructions12
 - SHSAM Input Worksheet.....12
 - SHSAM Tutorial.....13
- Pipe Hydraulics Criteria.....16
 - Pipe Configuration16
 - Headloss19
- SAFL Baffle Size Chart20
- Standard Details21
- Specification25
- Maintenance & Monitoring30
 - Visual Inspection30
 - Sump Cleaning.....30
- Nonstandard Designs.....32
 - Sump Structures with less than 3-ft of depth.....32
 - Curb to sump structure32

Essential Terminology:

SAFL Baffle:

- a perforated, stainless steel baffle
- bolts vertically into a sump structure for improved sediment capture

Sump structures:

- circular or rectangular structures
- one or more inlet pipes
- one outlet pipe
- depth below the outlet pipe (sump)

Applications:

The SAFL Baffle is a great choice for stormwater sediment removal in several situations:

- **Retrofits:** You are looking to improve the performance of your existing storm sewer infrastructure and have an existing sump structure that meets the criteria laid out in this guide.
- **Pretreatment:** You want to reduce maintenance of downstream BMPs like detention ponds, infiltration systems, and underground vaults.
- **Primary Treatment:** There is no room for other BMPs, or your project is low on funds, but you want to do something about stormwater sediment.

SAFL Baffle Concetpual Design Flowchart

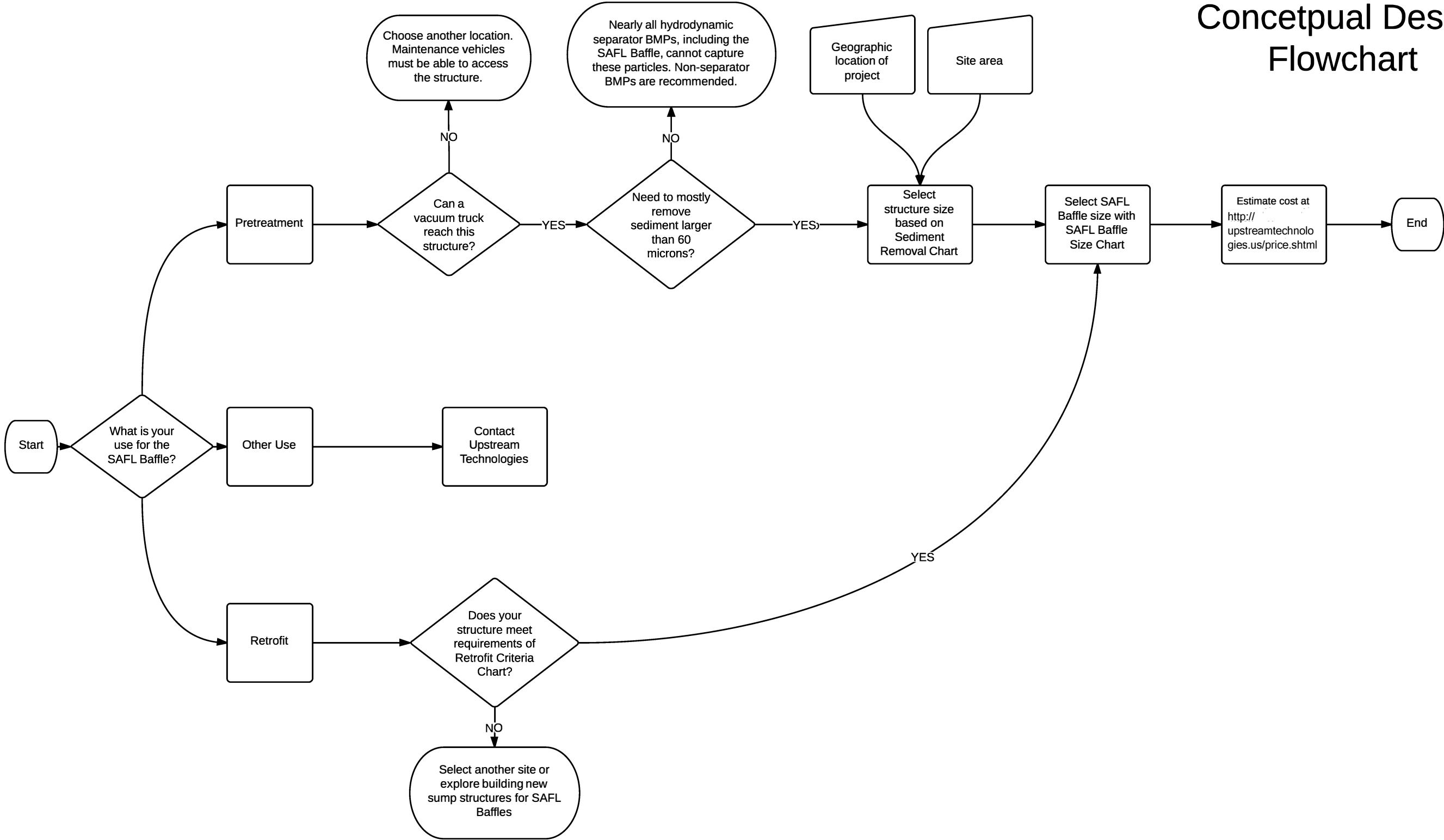

Retrofit Criteria

1. The structure can be round or square / rectangular
2. Sump depth should be 3 feet minimum (See dimension E on the next page)
3. Diameter or width of sump structure (Dimension W) = 3 feet minimum to 10 feet maximum
4. 75% of the flow must be horizontal
5. Manhole casting inner diameter must be 24 inches minimum
6. Inlet and outlet pipes must meet Pipe Hydraulics Criteria (discussed later in this guide)
7. See following page for further dimensioning.

SAFL BAFFLE SIZING REQUIREMENTS

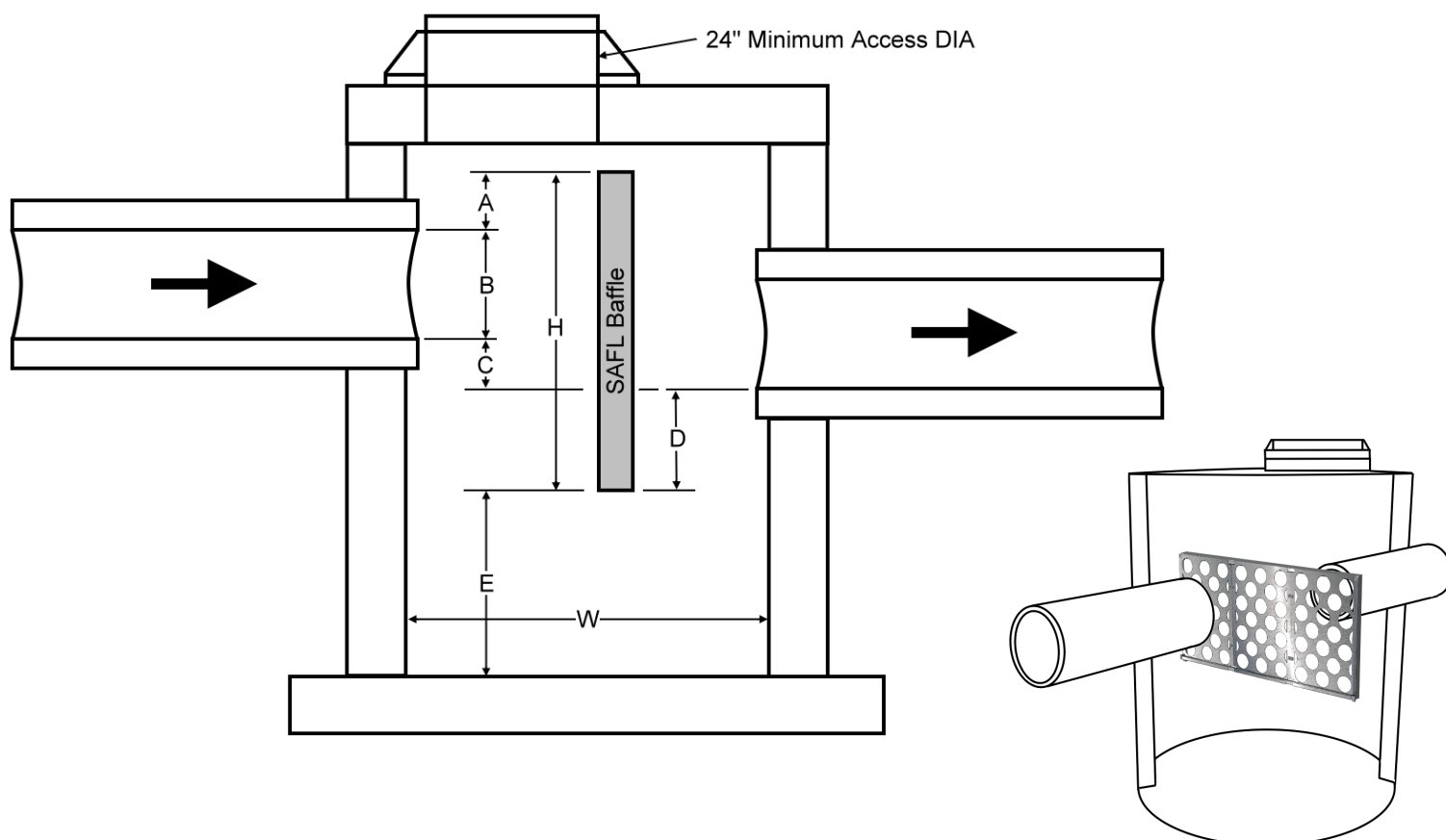

A	0 to 6" 6" is ideal
B	Inlet pipe inside diameter
C	0 to 6" 0" is ideal
D	12"
E	36" Minimum. 48" or greater is ideal and results in less frequent sump cleanout
W	W = Sump diameter if round or width if rectangular
H	Baffle height = A + B + C + D
Purchase Baffle Size	W x H View the complete list of Available Baffle Sizes
	Also see: Bracing Guide & Stacking Guide
NOTE 1	If H is greater than 57" two SAFL Baffles may be stacked.
NOTE 2	75% of flow must be horizontal. No more than 25% falling from above
NOTE 3	This detail does not cover sizing the sump for sediment removal efficiency. Contact Upstream for sump sizing or use SHSAM Software
NOTE 4	For more information, see our Design Guide

PATENT PROTECTED Patents: US #8663466B2 - US #8715507B2 - US #9506237B2 - CA #2742207

This generic detail does not encompass the sizing, fit, and applicability of the SAFL Baffle for this specific project. It is the ultimate responsibility of the design engineer to assure that the design is in compliance with all applicable laws and regulations. The SAFL Baffle is a patented technology of Upstream Technologies, Inc. Upstream Technologies does not approve plans, sizing, or system designs.

SAFL BAFFLE SIZING DETAIL
 UPSTREAM TECHNOLOGIES INC.
 5201 East River Road, Suite 303
 Fridley, MN 55421
 651-237-5123



SAFL BAFFLE BRACING REQUIREMENTS

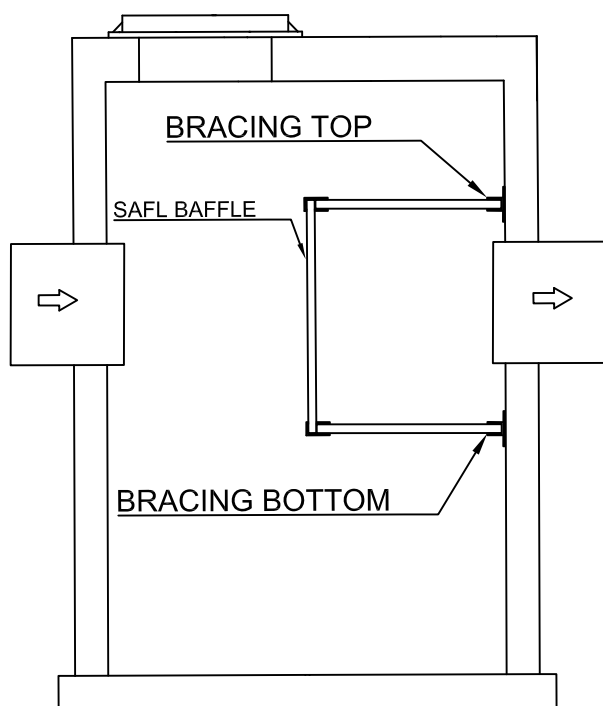

SIDE VIEW

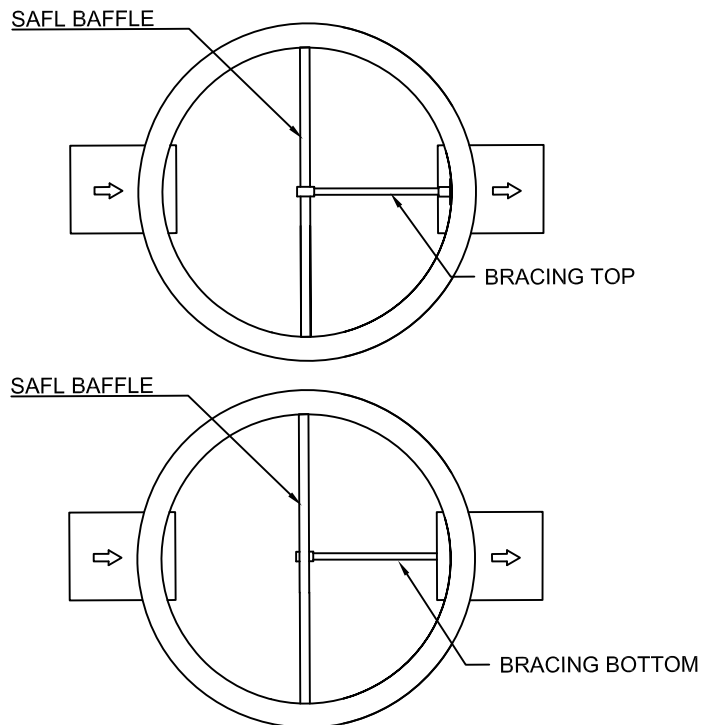

TOP VIEW

Guidance for Cross Bracing - SAFL Baffle

Pipe Inside Diameter (inches)	Bracing Needed Above This Flow (CFS)	Max Flow with 2 Braces (1 top, bottom)	Max Flow with 4 Braces (2 top, 2 bottom)
24	20	30	40
30	30	45	60
36	40	60	75
42	55	70	90
48	75	105	130
60	110	160	200

Note: Flows shown are maximum design flows with a slope of less than 3%. Contact Upstream Technologies if pipe slopes are 3% or greater.

Also see: [Stacking Guide](#) & [Sizing Guide](#)

PATENT PROTECTED Patents: US #8663466B2 - US #8715507B2 - US #9506237B2 - CA #2742207

This generic detail does not encompass the sizing, fit, and applicability of the SAFL Baffle for this specific project. It is the ultimate responsibility of the design engineer to assure that the design is in compliance with all applicable laws and regulations. The SAFL Baffle is a patented technology of Upstream Technologies, Inc. Upstream Technologies does not approve plans, sizing, or system designs.

SAFL BAFFLE BRACING DETAIL
 UPSTREAM TECHNOLOGIES INC.
 5201 East River Road, Suite 303
 Fridley, MN 55421
 651-237-5123



SAFL BAFFLE STACKING REQUIREMENTS

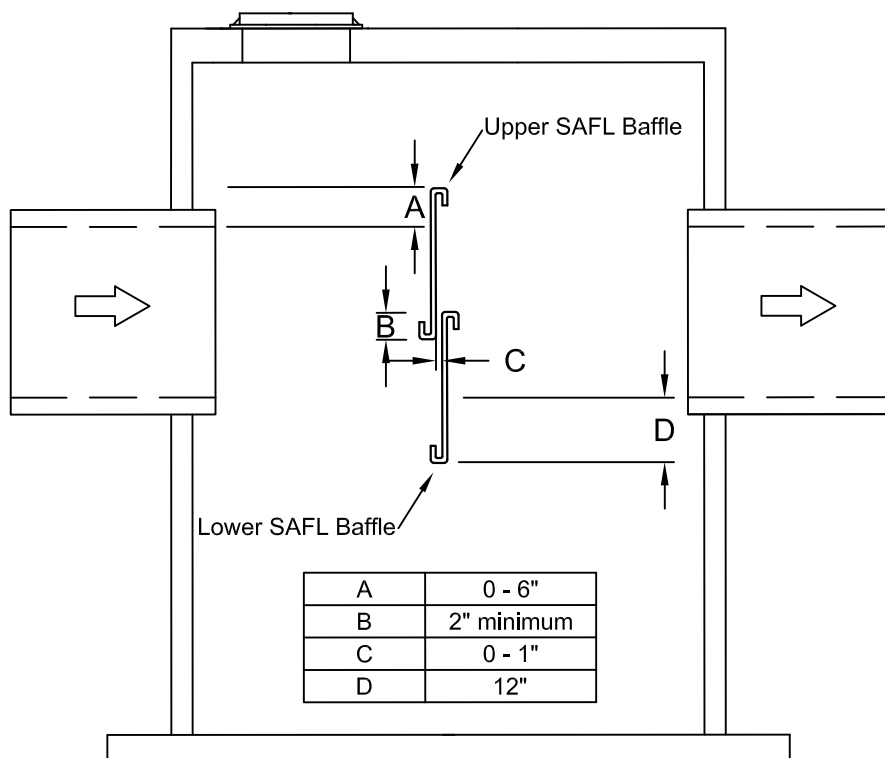

Bracing for Stacked Baffles

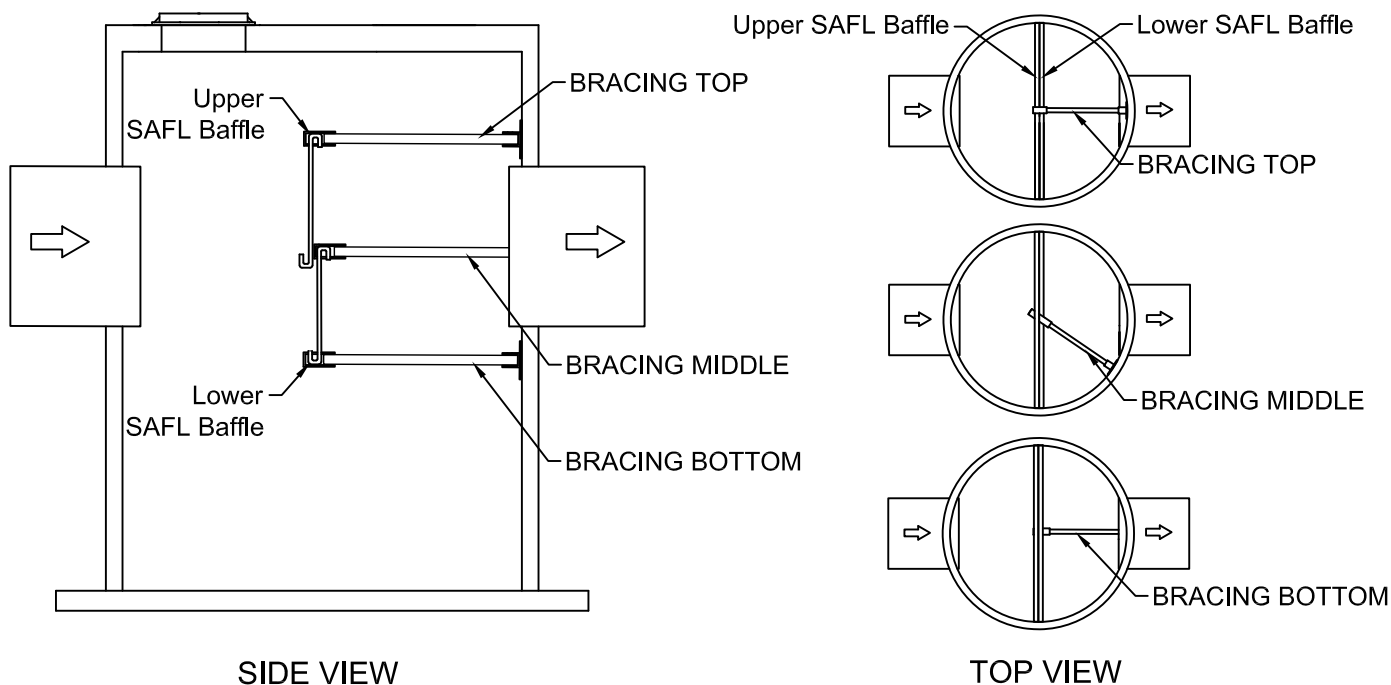

Also see: [Bracing Guide](#) & [Sizing Guide](#)

PATENT PROTECTED Patents: US #8663466B2 - US #8715507B2 - US #9506237B2 - CA #2742207

This generic detail does not encompass the sizing, fit, and applicability of the SAFL Baffle for this specific project. It is the ultimate responsibility of the design engineer to assure that the design is in compliance with all applicable laws and regulations. The SAFL Baffle is a patented technology of Upstream Technologies, Inc. Upstream Technologies does not approve plans, sizing, or system designs.

SAFL BAFFLE STACKING DETAIL
 UPSTREAM TECHNOLOGIES INC.
 5201 East River Road, Suite 303
 Fridley, MN 55421
 651-237-5123
www.upstreamtechnologies.us



Sediment Removal Charts

These six charts provide examples of sediment removal efficiency for various watershed sizes. Sediment removal efficiency is site specific, so final designs should utilize the SHSAM software to calculate it. Instructions are provided in the following section of this design guide beginning on Page 12.

Here are the assumptions used to generate these charts with SHSAM:

Area (acres):	1, 3, 7, 10
Impervious (%):	70
Hydraulic Length (ft):	381, 660, 1008, 1205
Average Slope (%):	1.5
CN (pervious):	70
Weather Station Precipitation:	Local, 15 minute
Water Temperature:	Local, average daily
Washout Included?:	Yes
Bypass?:	No
Sediment Distribution:	Janna-Omid

Janna-Omid Particle Size Distribution:

Particle Size (microns)	Percent Finer	Specific Gravity
1000	100	2.65
500	95	2.65
250	90	2.65
170	65	2.65
100	35	2.65
50	15	2.65
8	2	2.65
2	1	2.65

SHSAM estimated SAFL Baffle sediment removal for sample Minneapolis, Denver and Ocala watersheds.

Minneapolis, MN			% Removal			
Sump Depth (ft)	Structure Diameter (ft)	Pipe Diameter (inches)	1 acre	3 acres	7 acres	10 acres
4	4	18	59.9	30.5	12.8	7.2
5	5	24	75.2	49.9	30.5	21.5
3	6	24	77.1	52.5	32.8	24.0
6	6	30	84.4	63.7	45.8	36.9
6	8	36	89.9	73.2	56.8	48.5

Denver, CO			% Removal			
Sump Depth (ft)	Structure Diameter (ft)	Pipe Diameter (inches)	1 acre	3 acres	7 acres	10 acres
4	4	18	66.5	38.6	21.6	15.2
5	5	24	79.4	58.7	40.8	31.9
3	6	24	80.9	61.8	43.7	34.5
6	6	30	86.3	72.0	56.9	48.1
6	8	36	90.1	79.4	68.1	60.7

Ocala, FL			% Removal			
Sump Depth (ft)	Structure Diameter (ft)	Pipe Diameter (inches)	1 acre	3 acres	7 acres	10 acres
4	4	18	50.9	23.1	7.6	3.2
5	5	24	68.3	40.7	24.1	16.3
3	6	24	70.5	35.2	17.7	10.9
6	6	30	79.0	55.3	38.1	39.5
6	8	36	85.5	66.1	48.0	39.7

SHSAM estimated SAFL Baffle sediment removal for sample Seattle, Los Angeles and Newark watersheds.

Seattle, WA			% Removal			
Sump Depth (ft)	Structure Diameter (ft)	Pipe Diameter (inches)	1 acre	3 acres	7 acres	10 acres
4	4	18	76.9	47.9	29.1	21.5
5	5	24	87.9	70.6	52.2	41.6
3	6	24	85.3	63.1	43.5	33.7
6	6	30	93.3	82.5	69.8	60.9
6	8	36	95.8	88.1	79.7	73.4

Los Angeles, CA			% Removal			
Sump Depth (ft)	Structure Diameter (ft)	Pipe Diameter (inches)	1 acre	3 acres	7 acres	10 acres
4	4	18	72.2	40.4	20.8	13.9
5	5	24	84.7	61.8	40.1	30.0
3	6	24	81.7	55.6	33.7	24.3
6	6	30	91.1	75.6	56.7	46.4
6	8	36	94.4	83.4	68.5	59.4

Newark, NJ			% Removal			
Sump Depth (ft)	Structure Diameter (ft)	Pipe Diameter (inches)	1 acre	3 acres	7 acres	10 acres
4	4	18	73.3	50.3	31.1	22.1
5	5	24	83.7	65.4	47.7	38.8
3	6	24	81.0	60.2	41.3	32.3
6	6	30	89.3	75.5	59.8	51.7
6	8	36	92.5	82.1	68.6	61.0

SHSAM Instructions

SHSAM is a free tool for sizing a sump structure and SAFL Baffle. Use the following SHSAM Input Worksheet to organize your inputs required to run SHSAM. If not familiar with SHSAM, skip the SHSAM Input Worksheet and follow the sample SHSAM Tutorial.

SHSAM Input Worksheet

Watershed Information

Watershed Area _____ acres
 Impervious Fraction _____ %
 Hydraulic Length _____ feet
 Average Slope _____ %
 SCS Curve Number (pervious area) _____

Hydraulics

Bypass Y / N? _____ if Y, @ _____ cfs
 Sump Structure Diameter _____ inches
 Sump Depth _____ inches
 Inlet Pipe Diameter _____ inches
 Outlet Pipe Diameter _____ inches

Rainfall

Site Location _____
 Rainfall Data Set Location _____
 Analysis Period start _____ end _____

SHSAM has built in rainfall and temperature data for Chicago, IL; Dallas, TX; Denver, CO; Golden Valley, MN; Los Angeles, CA; Newark, NJ; Northfield, MN; Ocala, FL; Red Wing, MN; San Francisco, CA; Seattle, WA, St. Louis, MO; and Washington, DC.

Sediment

Particle Size (microns)	Percent Finer (%)	Specific Gravity

Note:

Verify with regulatory agency to determine sediment requirements

If acceptable, use SHSAM's built in sediment distributions

SHSAM allows use of custom particle data.

Inflow TSS Concentration _____ mg/l

SHSAM Tutorial

This section of the guide will help you run an example simulation in SHSAM for a watershed in the Minneapolis, MN area. Undoubtedly your watershed is not in Minneapolis, MN, but the principles remain the same. By selecting inputs that match your watershed, instead of the inputs in this guide, you can create a SHSAM simulation that is reliable for your design decisions. If SHSAM's built in drop down menus do not provide inputs that match your watershed's conditions, follow SHSAM's instructions for inputting custom data into the program.

For a more in-depth SHSAM tutorial, exploring SHSAM's limitations and advanced features, please watch our [SHSAM tutorial series](http://upstreamtechnologies.us/products/SAFL/shsam.shtml) on our Design Guide: (<http://upstreamtechnologies.us/products/SAFL/shsam.shtml>)

An example simulation:

1. Download SHSAM from <https://shsam.barr.com/>
2. Install SHSAM and start the program.
3. Read the first tab titled **1. Introduction**
4. Select the second tab, titled **2. Root Directory**. Set a root directory where SHSAM output files can be sent and input files can be placed. It is important to choose a file path that does not include spaces. For example, "C:\Users\Kurt\SHSAMOutputs" is an acceptable file path, but "C:\Users\Kurt\SHSAM Outputs" is not.
5. Select the third tab, titled **3. BMP**. Select the radio button titled **Standard Sumps with SAFL Baffle**. A pop up window will display, asking whether or not washout should be incorporated into the calculations. Select **Yes** for washout, and select **No** for a bypass.
6. Next, select the fourth tab, titled **4. Weather Station Precipitation**. From the top-most drop down menu, select the **Golden Valley** weather station precipitation to be used for the estimate. Each weather station collected data for many years. Select the range of dates that are deemed appropriate for the estimate. For this example, use the data from **1995 to 2007**. *Author's Note – If SHSAM does not provide acceptable precipitation data for your region, free-to-download 15 minute precipitation data can be found at <http://www.ncdc.noaa.gov/cdo-web/>. Select Precipitation Data, 15 minute and follow the subsequent instructions for download. For detailed instructions on how to complete this process, watch our [SHSAM video tutorial series](#).*
7. Select the fifth tab, titled **5. Particle Size Distribution**. Use the drop down menu to select the particle size distribution to represent the influent sediment entering the sump. For this example, choose **MNDOT Road Sand**. *Author's Note: Influent particle size distribution has a large effect on the performance of stormwater BMPs. If a particle size distribution analysis is not available for your site, I recommend performing several SHSAM simulations. Keep all watershed values constant, but change the particle size distribution from Mn/DOT Road Sand, OK110, to NURP, and compare how the removal efficiency of your BMP changes between simulations.*
8. Click on tab six, titled **6. Watershed Data**. Enter the drainage area, percent pervious, hydraulic length, average slope, and curve number for the watershed. For this example, use an Area of **3**

acres, an Impervious (%) of **85**, a Hydraulic Length (ft) of **700**, an Average Slope (%) of **2.5**, and a CN (pervious) of **70**.

9. Next, select the seventh tab, titled **7. Temperature**. Click **No** to use the drop down menu for water temperature data. From the drop down menu, select the **St. Paul 1991-2007** data. *Author's Note – If SHSAM's drop down temperature menu doesn't provide a suitable daily water/air temperature file, you can download this data at <http://www.ncdc.noaa.gov/cdo-web/>. View our [SHSAM video tutorial series](#) for detailed description of how to do this.*
10. For the final step of entering input parameters, select the eighth tab, titled **8. Influent Concentration / Count Sump Cleanings**. Enter the influent concentration of sediment reaching the sump to be **200 mg/L**. *Author's Note – if you have data about the concentration of sediment found in stormwater leaving your watershed, use that value for this input. However, if you do not have data, I recommend running several simulations where sediment influent concentration is varied. The removal efficiency of your device will not change as sediment influent concentration is increased, but the total poundage of sediment captured will change (and in turn, maintenance frequency).*
11. Press the button in the bottom right hand corner called **Run Model**.
12. Select **Tools--->Output Data** from the File Menu. Select the tab titled **Summary**. Scroll to the bottom of the Summary window to find a smaller "Summary" table. This table (consisting of 8 rows) summarizes the sediment capture data for various sized sump manholes equipped with a SAFL Baffle. *Author's Note – When performing a simulation with other BMPs, the number of rows making up the "Summary" table will vary.*
13. Within this smaller summary table, the column titled Model displays the different sump manhole sizes used for the simulation. 42 = 4-ft diameter by 2-ft deep sump manhole, 44 = 4-ft diameter by 4-ft deep sump manhole, etc.
14. The column titled Total Load shows the amount of sediment that traveled off of the simulated drainage area and ended up traveling into the sump manhole.
15. The column titled Total Load Removed shows the amount of sediment that the sump manhole equipped with a SAFL Baffle actually captured.
16. The column titled Removal Efficiency is the percentage of sediment that was captured in the sump manhole equipped with a SAFL Baffle with respect to the total amount of sediment that traveled into the system.
17. The next three columns display the dimensions of the sump manholes that were used for the simulation.
18. To compare the performance of the SAFL Baffle installed in a sump manhole to another device, I recommend copying and pasting the small "Summary" table into a spreadsheet program like Excel.
19. Next, exit out of the Output window. The Input Data window should still be up. Click on the third tab, titled **3. BMP**. Select a different device. A pop up window will display, asking whether or not

washout should be incorporated into the calculations. Select **Yes** for washout, and select **No** for a bypass. Some devices do not have washout or were not tested for washout. Simply click **OK** for these devices.

20. Click **Run Model**. Follow the previous instructions for reading outputs (Steps 11-17).

Pipe Hydraulics Criteria

The most effective SAFL Baffle installations have one inlet and one outlet pipe, located 180 degrees from each other (straight flow through). However, the SAFL Baffle can be used in a wide variety of pipe conditions. Based on your site hydraulics, ensure that your pipe configurations meet the criteria set by the following four figures. If your designs cannot meet this criteria, sediment removal estimates from SHSAM or Sediment Removal Charts may be unreliable.

Pipe Configuration

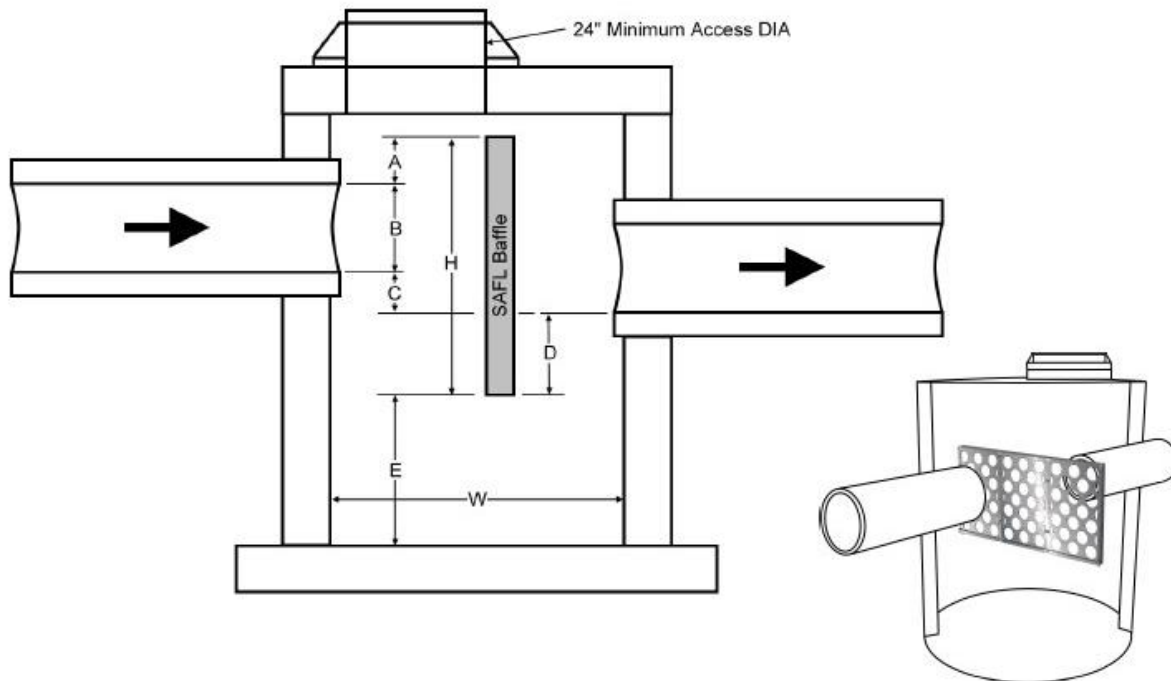

A	0 to 6" 6" is ideal
B	Inlet pipe inside diameter
C	0 to 6" 0" is ideal
D	12"
E	36" Minimum, 48" or greater is ideal and results in less frequent sump cleanout
W	W = Sump diameter if round or width if rectangular
H	Baffle height = A + B + C + D
Purchase Baffle Size	W x H View the complete list of Available Baffle Sizes
	Also see: Bracing Guide & Stacking Guide
NOTE 1	If H is greater than 57" two SAFL Baffles may be stacked.
NOTE 2	75% of flow must be horizontal. No more than 25% falling from above
NOTE 3	This detail does not cover sizing the sump for sediment removal efficiency. Contact Upstream for sump sizing or use SHSAM Software
NOTE 4	For more information, see our Design Guide

SAFL Baffle installations must have greater than 75% of the total drainage area draining through inlet pipes with pipe invert differentials, Δb , less than the diameter of the outlet pipe, d , **divided by two**. If not, sediment capture will be decreased.

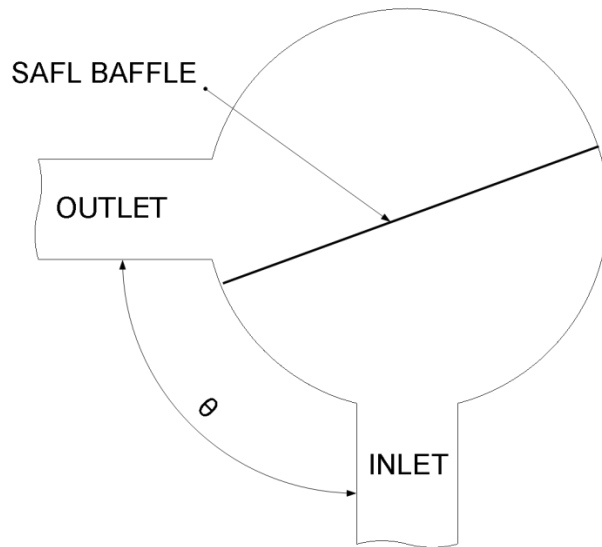

PLAN VIEW

Sump structures with inlet pipes located at angles other than 180 degrees from the outlet pipe are OK. However, an inlet pipe cannot be located less than 90 degrees from the outlet pipe.

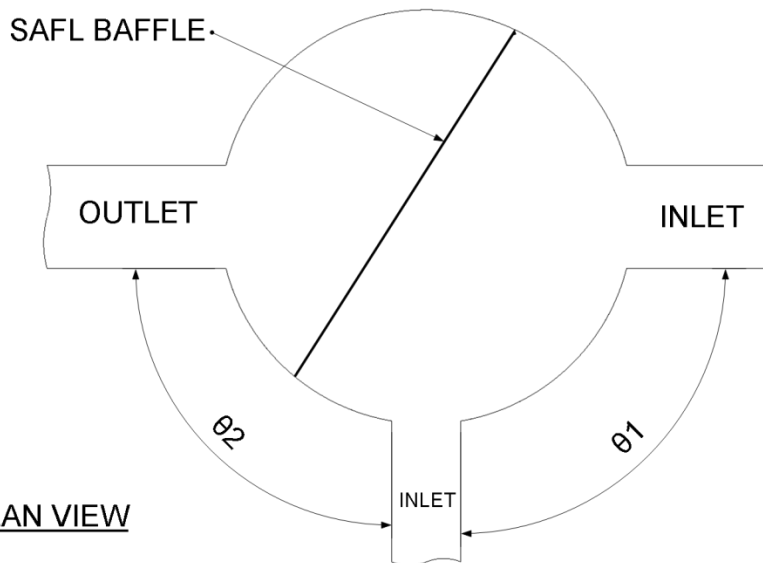

PLAN VIEW

SAFL Baffle installations with multiple inlet pipes work well. However, the angle between the two inlet pipes, θ_1 , cannot be greater than 110 degrees. Additionally, the angle from the outlet pipe to any inlet pipe, θ_2 , must be greater than or equal to 90 degrees.

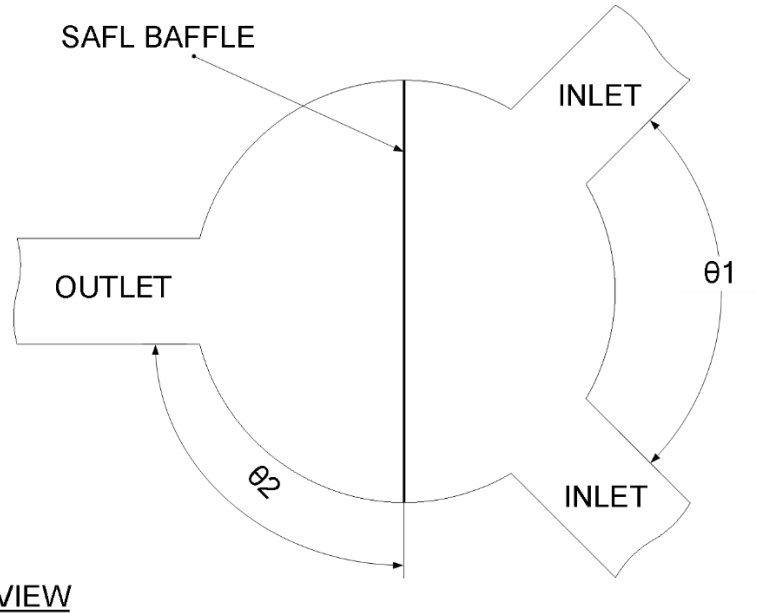

Here is another example of multiple inlet pipes. The angle between the two inlet pipes, θ_1 , cannot be greater than 110 degrees. Additionally, the angle from the outlet pipe to any inlet pipe, θ_2 , must be greater than or equal to 90 degrees.

Flow from Above

The SAFL Baffle needs horizontal flow through the structure in order to function as intended. However, it can accommodate flow from above, provided that there is also horizontal flow that is at least 3 times the flow from above. The SAFL Baffle will not work in a catch basin that only has flow from above (from a surface grate or curb inlet).

Headloss

The SAFL Baffle causes headloss within sump structures, but is generally small enough that it does not prohibitively affect hydraulic grade lines for storm sewer designs. The chart below shows laboratory testing of a 6-ft diameter, 3-ft deep, circular sump manhole structure with and without a SAFL Baffle. Likely, your structure has different dimensions than the tested structure, so a conservative estimate will have to be made to determine how headloss from a SAFL Baffle will affect your design.

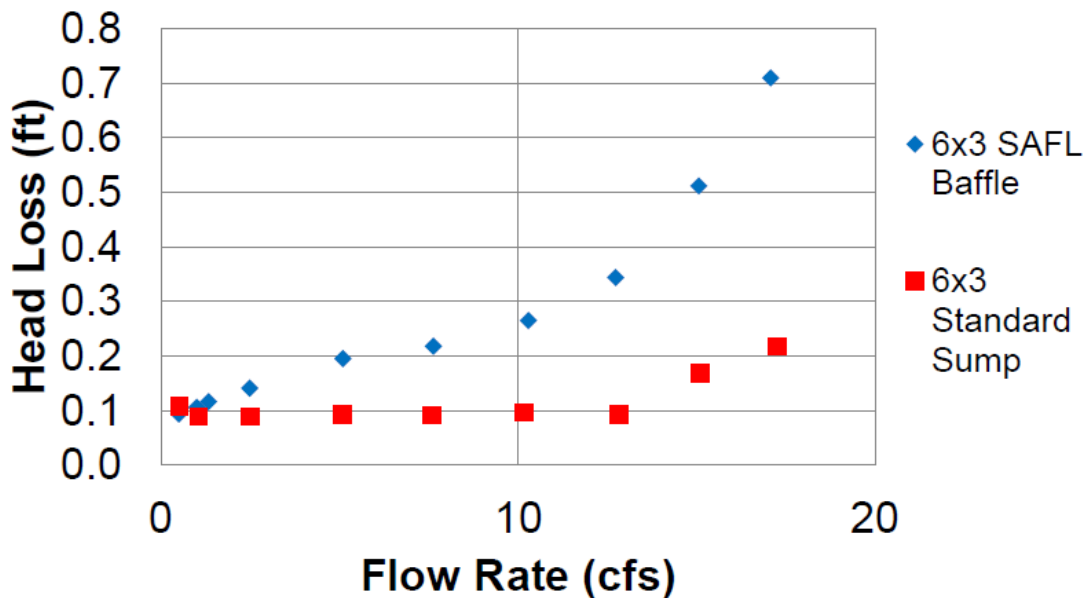

SAFL Baffle Size Chart

Use the chart below to determine the SAFL Baffle size you need. If you used SHSAM to determine your sump structure size, use those sump structure dimensions within this form. If you simply want to improve sediment capture and are not looking to meet a specific goal, use this form without a SHSAM calculation. If you want to use a structure with a larger diameter or pipe sizes, give us a call at 651-237-5123 for options. Pricing information can be found at (<http://upstreamtechnologies.us/price.shtml>)

Manhole Diameter or Width (Inches)	Diameter of Largest Inlet Pipe (Inches)	SAFL Baffle Width x Heights (Inches)
48	15	48 x 36
48	24	48 x 46
60	15	60 x 36
60	24	60 x 46
60	36	60 x 57
72	15	72 x 36
72	24	72 x 46
72	36	72 x 57
84	15	84 x 36
84	24	84 x 46
84	36	84 x 57
84	54	2 - 84 x 36 STACKED
96	24	96 x 46
96	36	96 x 57
96	54	2 - 96 x 36 STACKED

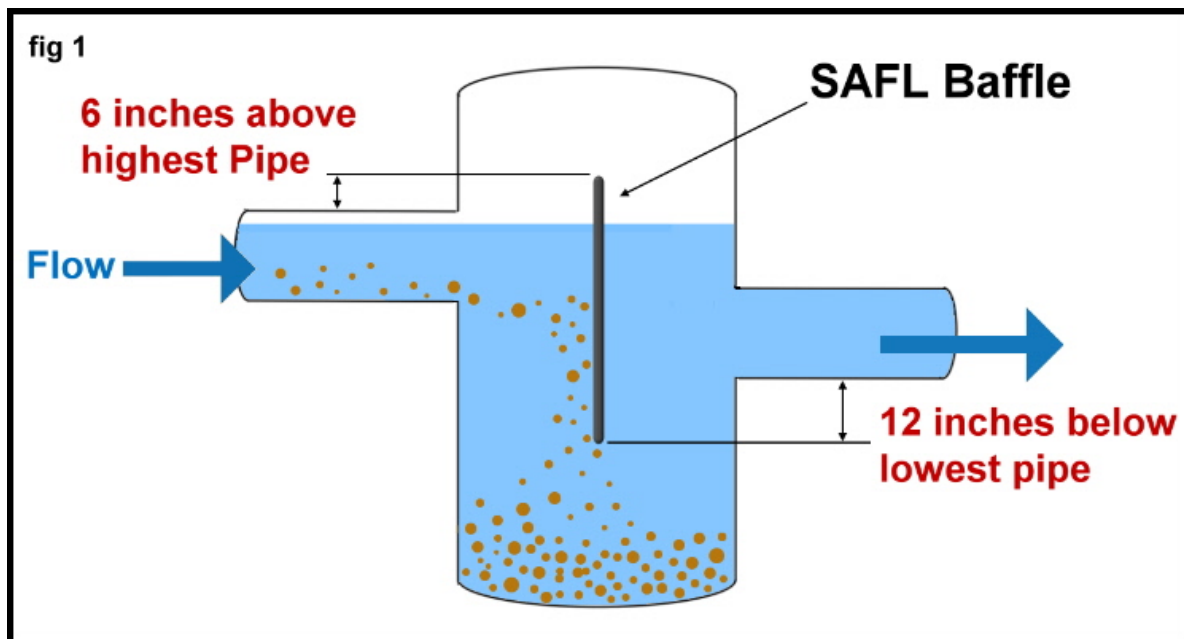

MANHOLE/CATCH BASIN COVER AND FRAME – 27" MIN. CLEAR OPENING
 SMALLER OPENING MAY REQUIRE BAFFLE INSTALLATION PRIOR TO PLACING CASTING
 STRUCTURES GREATER THAN 60" DIA. MAY REQUIRE SECOND CASTING FOR CLEANING SUMP

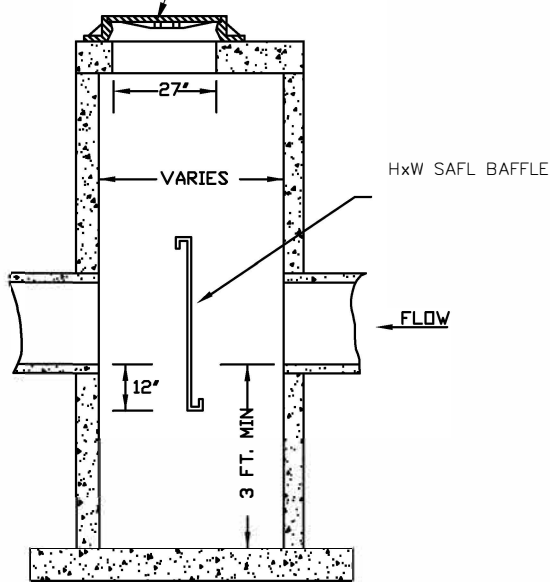

**SAFL BAFFLE INSTALLATION
 Detail**

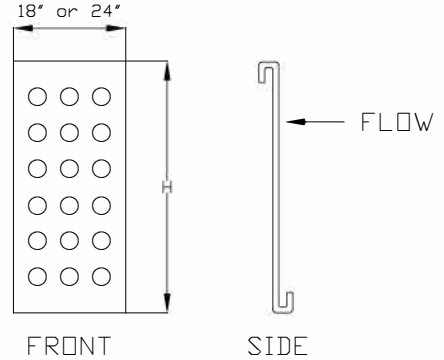

WIDTH ADJUSTMENT FOR PANEL SIZES

2- 18" PANELS	32"MIN	36"MAX	4"TOTAL
2- 24" PANELS	44"MIN	48"MAX	4"TOTAL
3- 18" PANELS	46"MIN	54"MAX	8"TOTAL
3- 24" PANELS	64"MIN	72"MAX	8"TOTAL

**SAFL BAFFLE PANEL
 Detail**

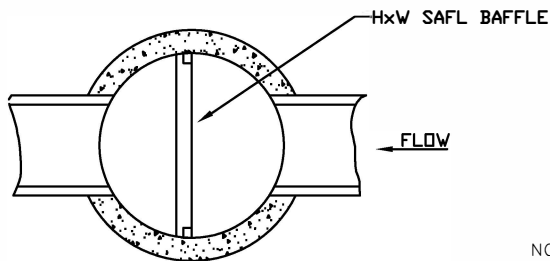

**SAFL BAFFLE INSTALLATION
 Plan**

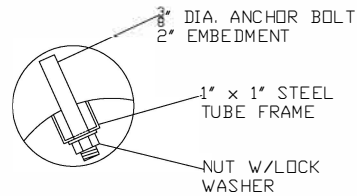

**SAFL BAFFLE ATTACHMENT BOLT
 Detail**

NOTES:

- 1) UPSTREAM TECHNOLOGIES INC. IS THE EXCLUSIVE LICENSEE OF THE SAFL BAFFLE
- 2) CONTRACTOR MUST VERIFY LOCATION OF CASTING AND STEPS PRIOR TO INSTALLATION OF STRUCTURE.
- 3) CONTRACTOR STRUCTURES GREATER THAN 72" REQUIRE SECOND CASTING FOR MAINTENANCE
- 4) THIS GENERIC DETAIL DOES NOT ENCOMPASS THE SIZING, FIT, AND APPLICABILITY OF THE SAFL BAFFLE FOR THIS SPECIFIC PROJECT. IT IS THE ULTIMATE RESPONSIBILITY OF THE DESIGN ENGINEER TO ASSURE THAT THE DESIGN IS IN COMPLIANCE WITH ALL APPLICABLE LAWS AND REGULATIONS. THE SAFL BAFFLE IS A PATENTED TECHNOLOGY OF UPSTREAM TECHNOLOGIES, INC. UPSTREAM TECHNOLOGIES DOES NOT APPROVE PLANS, SIZING, OR SYSTEM DESIGNS.

THROUGH PIPE CONFIGURATION

SAFL BAFFLE STANDARD DETAIL
 UPSTREAM TECHNOLOGIES
 5201 East River Road, Suite 303
 Fridley, MN 55421
 651-237-5123

**PATENT
 PROTECTED**



MANHOLE/CATCH BASIN COVER AND FRAME – 27" MIN. CLEAR OPENING
 SMALLER OPENING MAY REQUIRE BAFFLE INSTALLATION PRIOR TO PLACING CASTING
 STRUCTURES GREATER THAN 60" DIA. MAY REQUIRE SECOND CASTING FOR CLEANING SUMP

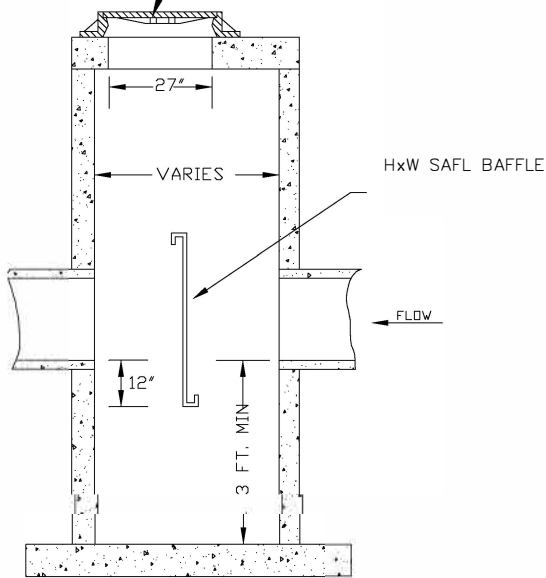

**SAFL BAFFLE INSTALLATION
 Detail**

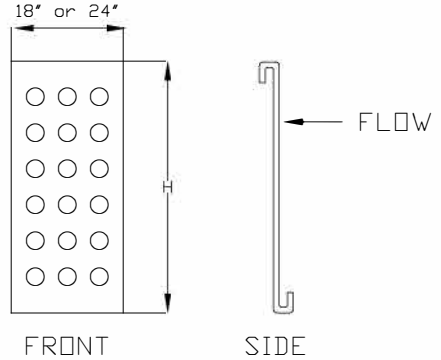

**SAFL BAFFLE PANEL
 Detail**

WIDTH ADJUSTMENT FOR PANEL SIZES

2- 18" PANELS	32"MIN	36"MAX	4"TOTAL
2- 24" PANELS	44"MIN	48"MAX	4"TOTAL
3- 18" PANELS	46"MIN	54"MAX	8"TOTAL
3- 24" PANELS	64"MIN	72"MAX	8"TOTAL

MOUNT BAFFLE AS CLOSE TO OUTLET PIPE AS ALLOWABLE,
 AND ROTATE THE BAFFLE AS NEAR TO PERPENDICULAR TO
 INLET PIPE AS POSSIBLE

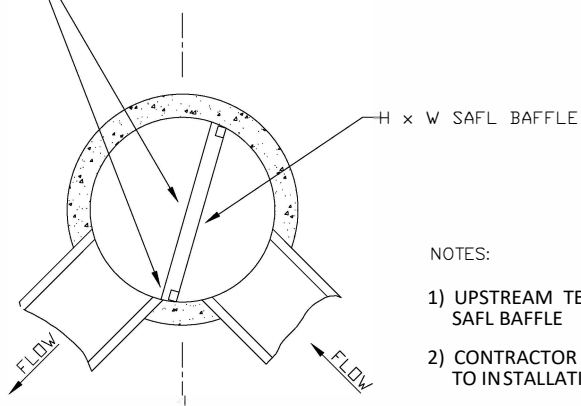

**SAFL BAFFLE INSTALLATION
 Plan**

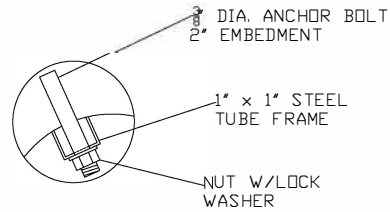

**SAFL BAFFLE ATTACHMENT BOLT
 Detail**

NOTES:

- 1) UPSTREAM TECHNOLOGIES INC. IS THE EXCLUSIVE LICENSEE OF THE SAFL BAFFLE
- 2) CONTRACTOR MUST VERIFY LOCATION OF CASTING AND STEPS PRIOR TO INSTALLATION OF STRUCTURE.
- 3) CONTRACTOR STRUCTURES GREATER THAN 72" REQUIRE SECOND CASTING FOR MAINTENANCE
- 4) THIS GENERIC DETAIL DOES NOT ENCOMPASS THE SIZING, FIT, AND APPLICABILITY OF THE SAFL BAFFLE FOR THIS SPECIFIC PROJECT. IT IS THE ULTIMATE RESPONSIBILITY OF THE DESIGN ENGINEER TO ASSURE THAT THE DESIGN IS IN COMPLIANCE WITH ALL APPLICABLE LAWS AND REGULATIONS. THE SAFL BAFFLE IS A PATENTED TECHNOLOGY OF UPSTREAM TECHNOLOGIES, INC. UPSTREAM TECHNOLOGIES DOES NOT APPROVE PLANS, SIZING, OR SYSTEM DESIGNS.

NINETY DEGREE PIPE CONFIGURATION

SAFL BAFFLE STANDARD DETAIL
 UPSTREAM TECHNOLOGIES
 5201 East River Road, Suite 303
 Fridley, MN 55421
 651-237-5123

**PATENT
 PROTECTED**



MANHOLE/CATCH BASIN COVER AND FRAME – 27" MIN. CLEAR OPENING
 SMALLER OPENING MAY REQUIRE BAFFLE INSTALLATION PRIOR TO PLACING CASTING
 STRUCTURES GREATER THAN 60" DIA. MAY REQUIRE SECOND CASTING FOR CLEANING SUMP

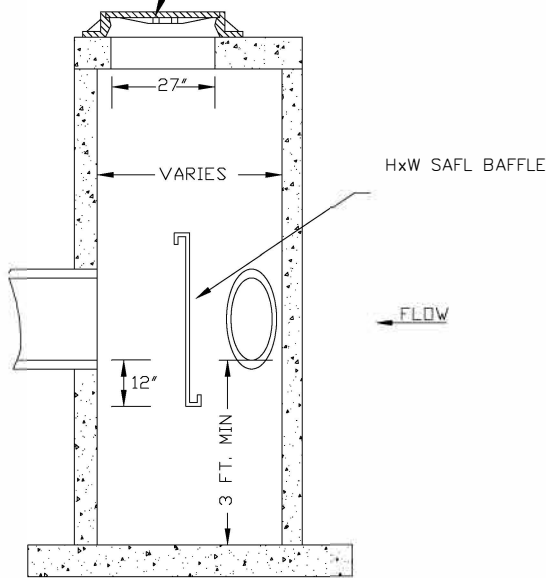

**SAFL BAFFLE INSTALLATION
 Detail**

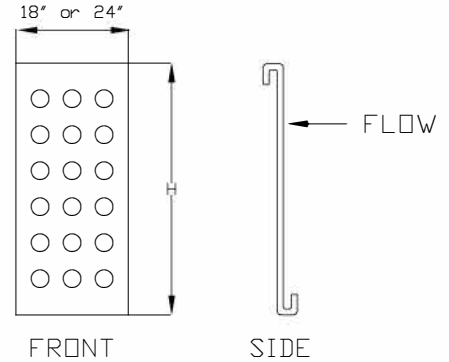

WIDTH ADJUSTMENT FOR PANEL SIZES

2- 18" PANELS	32"MIN	36"MAX	4"TOTAL
2- 24" PANELS	44"MIN	48"MAX	4"TOTAL
3- 18" PANELS	46"MIN	54"MAX	8"TOTAL
3- 24" PANELS	64"MIN	72"MAX	8"TOTAL

**SAFL BAFFLE PANEL
 Detail**

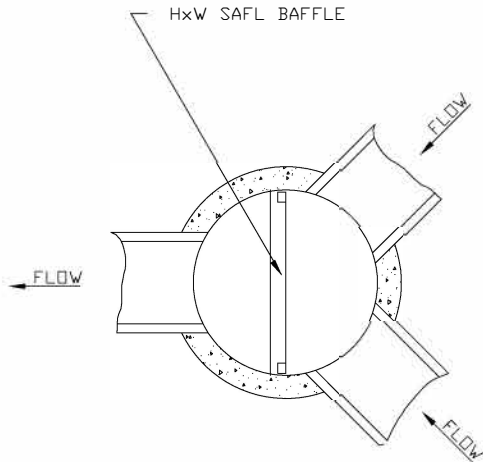

**SAFL BAFFLE INSTALLATION
 Plan**

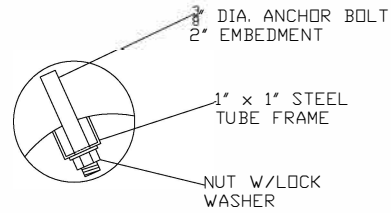

**SAFL BAFFLE ATTACHMENT BOLT
 Detail**

NOTES:

- 1) UPSTREAM TECHNOLOGIES INC. IS THE EXCLUSIVE LICENSEE OF THE SAFL BAFFLE
- 2) CONTRACTOR MUST VERIFY LOCATION OF CASTING AND STEPS PRIOR TO INSTALLATION OF STRUCTURE.
- 3) CONTRACTOR STRUCTURES GREATER THAN 72" REQUIRE SECOND CASTING FOR MAINTENANCE
- 4) THIS GENERIC DETAIL DOES NOT ENCOMPASS THE SIZING, FIT, AND APPLICABILITY OF THE SAFL BAFFLE FOR THIS SPECIFIC PROJECT. IT IS THE ULTIMATE RESPONSIBILITY OF THE DESIGN ENGINEER TO ASSURE THAT THE DESIGN IS IN COMPLIANCE WITH ALL APPLICABLE LAWS AND REGULATIONS. THE SAFL BAFFLE IS A PATENTED TECHNOLOGY OF UPSTREAM TECHNOLOGIES, INC. UPSTREAM TECHNOLOGIES DOES NOT APPROVE PLANS, SIZING, OR SYSTEM DESIGNS.

MULTIPLE INLET PIPE CONFIGURATION

SAFL BAFFLE STANDARD DETAIL
 UPSTREAM TECHNOLOGIES
 5201 East River Road, Suite 303
 Fridley, MN 55421
 651-237-5123

**PATENT
 PROTECTED**



MANHOLE/CATCH BASIN COVER AND FRAME – 27" MIN. CLEAR OPENING
 SMALLER OPENING MAY REQUIRE BAFFLE INSTALLATION PRIOR TO PLACING CASTING
 STRUCTURES GREATER THAN 60" DIA. MAY REQUIRE SECOND CASTING FOR CLEANING SUMP

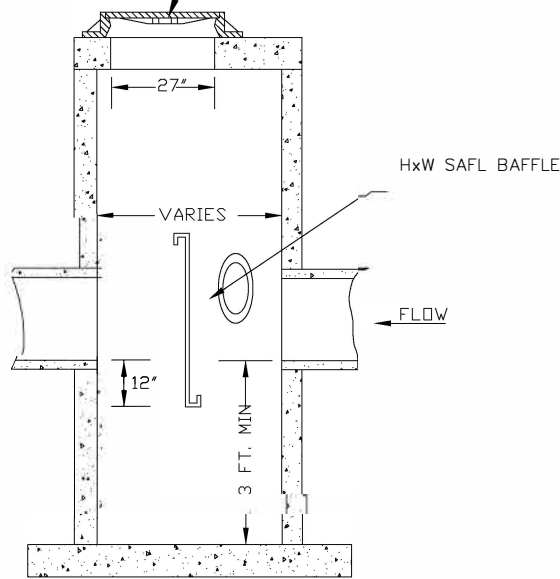

SAFL Baffle Installation
Detail

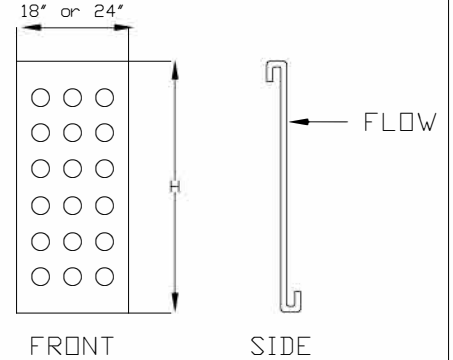

WIDTH ADJUSTMENT FOR PANEL SIZES

2- 18" PANELS	32"MIN	36"MAX	4"TOTAL
2- 24" PANELS	44"MIN	48"MAX	4"TOTAL
3- 18" PANELS	46"MIN	54"MAX	8"TOTAL
3- 24" PANELS	64"MIN	72"MAX	8"TOTAL

SAFL Baffle Panel
Detail

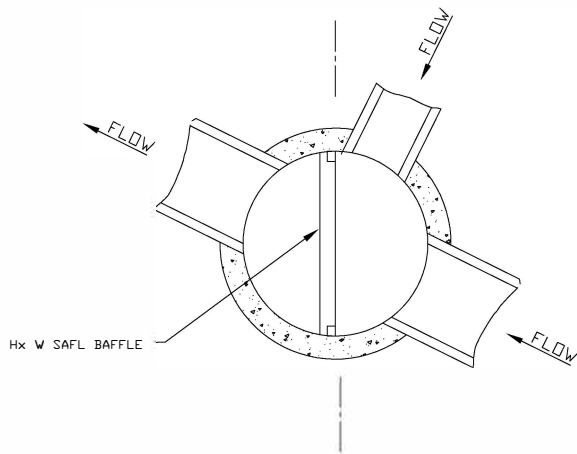

SAFL Baffle Installation
Plan

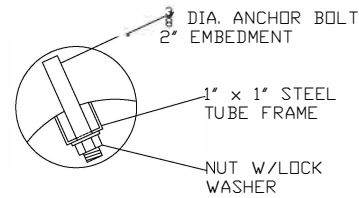

SAFL Baffle Attachment Bolt
Detail

NOTES:

- 1) UPSTREAM TECHNOLOGIES INC. IS THE EXCLUSIVE LICENSEE OF THE SAFL BAFFLE
- 2) CONTRACTOR MUST VERIFY LOCATION OF CASTING AND STEPS PRIOR TO INSTALLATION OF STRUCTURE.
- 3) CONTRACTOR STRUCTURES GREATER THAN 72" REQUIRE SECOND CASTING FOR MAINTENANCE
- 4) THIS GENERIC DETAIL DOES NOT ENCOMPASS THE SIZING, FIT, AND APPLICABILITY OF THE SAFL BAFFLE FOR THIS SPECIFIC PROJECT. IT IS THE ULTIMATE RESPONSIBILITY OF THE DESIGN ENGINEER TO ASSURE THAT THE DESIGN IS IN COMPLIANCE WITH ALL APPLICABLE LAWS AND REGULATIONS. THE SAFL BAFFLE IS A PATENTED TECHNOLOGY OF UPSTREAM TECHNOLOGIES, INC. UPSTREAM TECHNOLOGIES DOES NOT APPROVE PLANS, SIZING, OR SYSTEM DESIGNS.

SIDE INLET PIPE CONFIGURATION

SAFL BAFFLE STANDARD DETAIL
 UPSTREAM TECHNOLOGIES
 East River Road, Suite 303
 Fridley, MN 55421
 651-237-5123

**PATENT
 PROTECTED**



Specification

SECTION XX XX XX

SAFL BAFFLE

(Items highlighted in yellow must be modified to fit the specific project)

PART 1 GENERAL

1.01 SUMMARY

- A. Section Includes:
 - 1. Materials
 - 2. Site Preparation
 - 3. Foundation Placement
 - 4. Modular Block Unit Placement
 - 5. Backfill Placement
 - 6. Compaction

- B. Related Sections:
 - 1. Section XX XX XX – Sump Manhole
 - 2. Section XX XX XX – Castings (Be sure to specify 27-inch inside diameter castings on manholes with SAFL Baffle)

- C. Method of Measurement:
 - 1. Measure per complete baffle assembly installed.

- D. Basis of Payment:
 - 1. Payment shall cover supply and installation of the SAFL Baffle and other appurtenant materials required for installation as shown on the construction drawings. It shall include all compensation for labor, materials, supplies, and equipment associated with installation of the SAFL Baffle in a sump manhole.
 - 2. Payment for the SAFL Baffle will be based on the Contract Unit Price listed on the Bid Form.

1.02 REFERENCES

- A. All stainless steel shall be Type 304.

- B. ASTM
 - 1. A380 – Standard Practice for Cleaning, Descaling, and Passivation of of Stainless Steel Parts, Equipment, and Systems

- C. ANSI:
 - 1. B 18.2 – Standard Dimensions for Bolts

- D. SHSAM software by Barr Engineering, available for download at: <https://shsam.barr.com/>

1.03 DESCRIPTION

- A. Furnish and install SAFL Baffles as manufactured by Upstream Technologies Inc or approved equal, to the dimensions and elevations shown on the shop drawings.

- B. Furnish and install appurtenant materials required for installation of the SAFL Baffles or approved equal as shown on the shop drawings.

- C. The average sediment removal efficiency of the sump manhole with the SAFL Baffle or approved equal must be []% or higher, according to the SHSAM software output, using the following inputs:
 - 1. 15-minute Rainfall data from the NOAA weather station at [], from years [] through []
 - 2. Janna-Omid Particle Size Distribution
 - 3. Watershed size of [] acres
 - 4. Hydraulic length of [] feet
 - 5. []% impervious area
 - 6. Average slope of []%

7. Curve Number of [REDACTED] for the pervious area
8. Water temperature data from [REDACTED], years [REDACTED] - [REDACTED]
9. Influent concentration of [REDACTED] mg/L.

D. There must be no re-suspension of sediment from the sump (all sediment in the sump before the storm event must remain in the sump) during flows of up to 1.5 times the 10-year storm flow for the storm sewer system, which is [REDACTED].

1.04 SUBMITTALS

- A. Shop drawings of each sump manhole shall indicate dimensions and bottom elevation of the SAFL Baffle, as well as the location and orientation of the SAFL Baffle within the manhole.
- B. Manufacturer's Data:
 1. Installation manual.
 2. A letter from the manufacturer, signed by an officer, that all stainless steel is Type 304.
- C. Approved Equal:
 1. Installation manual.
 2. Specification from manufacturer.
 3. Design calculations demonstrating that the approved equal has been sized properly for the flow from the design storm event.
 4. Analysis using SHSAM software.
 - a. The average sediment removal efficiency for the proposed equal device must be equal to or greater than the average sediment removal efficiency for the SAFL baffle/sump manhole shown in the construction plans.
 - b. Submit all of the input values used in the analysis and the output files.
 5. For devices not included in the SHSAM software, submit the following.
 - a. a plot of sediment removal efficiency versus Peclet Number for the approved equal. This plot must be based on laboratory testing of the approved equal device that meets the following requirements:

- 1) Testing at 100%, 75%, 50%, and 25% of maximum flow rate for treatment.
 - 2) Sediment concentration of 200mg/L
 - 3) Sediment consists 1/3 each of 545 μ m, 335.5 μ m, and 107 μ m particles, each sieved to prevent particle size overlap.
 - 4) These procedures are described in more detail in "Improved Standard Sumps as Best Management Practice for Stormwater Treatment" found in the Conference Proceedings, Low Impact Development 2010: Redefining Water in the City, ASCE 2010.
- b. Plot of effluent concentration versus flow rate. This plot must be based on laboratory testing of the approved equal device that meets the following requirements:
- 1) A means of accurately weighing the sediment in the sump before and after each test.
 - 2) Sediment consisting of US Silica Sand F-110 with a mean bulk density of 107pcf.
 - 3) Run multiple tests with flow rates varying from 0.5 to 1.5 times the maximum flow rate for treatment as recommended by the manufacturer.
 - 4) Sort, dry, and weigh the sediment in the sump before and after each test.
 - 5) This series of tests will be repeated for each different size/configuration of alternative device that is to be installed on this project.
 - 6) These procedures are described in more detail in "Improved Standard Sumps as Best Management Practice for Stormwater Treatment" found in the Conference Proceedings, Low Impact Development 2010: Redefining Water in the City, ASCE 2010.

1.05 SAMPLING AND TESTING

- A. The Owner or authorized representative shall be accorded proper facilities to inspect and sample baffle panels/frames from lots ready for delivery. The Contractor shall notify the authorized representative in writing a minimum of 5 calendar days prior to shipment of materials.
- B. The Contractor shall establish and maintain quality control for the work under this section to assure compliance with contract requirements and maintain records of its quality control for all construction operations including but not limited to the following:
 - 1. Alignment Tolerances:
 - a. Horizontal
 - b. Vertical
 - c. Plumbness
 - d. Gaps between baffle units or between baffle units and wall of sump.
 - 2. Torque applied to concrete anchor bolts at the frame side rails and torque applied to eye-bolts and set screws during assembly of the SAFL baffle shall be to manufacturer's specifications.

1.06 QUALITY ASSURANCE

- A. Preinstallation Meetings: Conduct conference at Site to comply with the requirements of Section **XX XX XX**.

1.07 DELIVERY, STORAGE, AND HANDLING

- A. Check the materials upon delivery to assure that proper material has been received.
- B. Store the SAFL Baffles in an area where they will be protected from construction traffic and caustic/corrosive chemicals.
- C. Prevent excessive mud, wet cement, grout, epoxy and like materials from affixing themselves to the materials until each SAFL Baffle is installed and accepted. Damaged

material shall not be installed in any manhole and shall be replaced at no additional cost to Owner.

PART 2 PRODUCTS

2.01 MATERIALS

- A. Baffle Panels
 - 1. Physical Properties:
 - a. Stainless Steel:
 - 1) Shall be Type 304
 - 2) Minimum yield strength shall be 31,000 psi.
 - b. Minimum dimensions as follows:
 - 1) Unit width: 18 or 24 inches
 - 2) Unit Height: 34, 44, or 54 inches
 - 3) Thickness: 1/8 inch
- B. Frame
 - 1. Shall consist of 1" x 1" square stainless steel tube with 1/8" thick walls
 - 2. Connector on top and bottom frame rails shall consist of a solid square stainless steel bar measuring 7/8" x 7/8" in cross section.
- C. Anchor Bolts
 - 1. Must be 3/8" diameter
 - 2. Must have a mechanism that expands against the sides of a hole drilled in the concrete sump wall, to secure the bolt.
 - 3. Minimum pullout strength of each anchor shall be 2200 pounds and minimum shear strength shall be 2500 pounds.
- D. Screws and Bolts:
 - 1. Mn/DOT 3319.2E

PART 3 EXECUTION

3.01 INSTALLATION PRIOR TO DELIVERY

- A. The SAFL Baffle may be installed in a new manhole at the precast concrete plant, prior to delivery to the project site.
- B. The SAFL Baffle must be installed perpendicular to the inlet pipe, at the horizontal midpoint of the sump.
- C. Use 3/8" diameter bolts, cast into the concrete manhole wall, or use 3/8" diameter anchor bolts installed in a hole drilled in the concrete wall. Anchor bolts must be embedded 2 inches into the concrete sump wall and have a mechanism that expands against the sides of the drilled hole.
- D. The bottom of the SAFL Baffle shall be established at the elevation shown on the plans, with a tolerance of +/- 0.5 inch.
- E. The top and bottom rails of the baffle must be level, with no tolerance on levelness.
- F. Follow the manufacturer's installation instructions.
- G. The baffle panels must be vertical (plumb) when the installation is complete.
- H. Upon completion of installation, baffle panels may overlap as much as 2 inches, or the edges of adjacent panels may touch one another without overlapping. However, no gap is allowed between baffle panels.

3.02 INSTALLATION ON-SITE

- A. The SAFL Baffles may be installed on-site, after the manholes have been constructed.
- B. It is the contractor's responsibility to have all OSHA required safety equipment for confined space entry. It is also the contractor's responsibility to comply with all OSHA rules and procedures for confined space entry, and any other OSHA rules which are applicable for this work.

- C. Follow manufacturer's instructions for installation.
- D. The SAFL Baffle must be installed perpendicular to the inlet pipe, at the horizontal midpoint of the sump.
- E. The bottom of the SAFL Baffle shall be established at the elevation shown on the plans, with a tolerance of +/- 0.5 inch.
- F. Use 3/8" diameter bolts, cast into the concrete manhole wall, or use 3/8" diameter anchor bolts installed in a hole drilled in the concrete wall. Anchor bolts must be embedded 2 inches into the concrete sump wall and have a mechanism that expands against the sides of the drilled hole.
- G. The top and bottom rails of the baffle must be level, with no tolerance on levelness.
- H. The baffle panels must be vertical (plumb) when the installation is complete.
- I. Upon completion of installation, baffle panels may overlap as much as 2 inches, or the edges of adjacent panels may touch one another without overlapping. However, no gap is allowed between baffle panels.

3.03 APPROVED EQUAL

- A. Basis for approval – devices in the SHSAM software.
 - 1. Sediment removal efficiency from SHSAM software output that meets or exceeds the average sediment removal efficiency given in section 1.03(C).
 - 2. Meets or exceeds the re-suspension requirements in section 1.03(D).
 - 3. Device must be able to be cleaned out/emptied from above using a vacuum truck, without dismantling the device or a worker entering the device.
 - 4. Acceptance is subject to the review of both the engineer and the Owner.
- B. Basis for approval – devices not in SHSAM software.
 - 1. The plot of the efficiency versus Peclet number for the approved equal must plot on or above the plot for the SAFL Baffle,

which is plotted on a semi-logarithmic scale and defined as follows:

END OF SECTION

<i>Peclet Number (Pe) x-axis</i>	<i>Removal Efficiency (η) y-axis</i>
0.01	0%
0.1	5%
0.3	12%
0.5	22%
1.0	40%
2.0	75%
3.0	100%
10.0	100%
20.0	100%

2. The plot of effluent concentration versus flow rate for the approved equal must be at or below the plot for the SAFL Baffle.
 3. Device must be able to be cleaned out/emptied from above using a vactor truck, without dismantling the device or a worker entering the device.
 4. Acceptance is subject to review of both the engineer and the Owner.
- C. If an equivalent device is approved, the contractor will need to supply a specification from the device manufacturer that describes the material and installation requirements of that device. This specification will govern the installation of the approved equal.

3.04 QUALITY CONTROL

- A. Establish and maintain quality control for the work under this section to assure compliance with contract requirements and maintain records of its quality control for all construction operations including but not limited to the following:
 1. Alignment Tolerances:
 - a. Horizontal
 - b. Vertical
 - c. Plumbness
 - d. Gaps between wall units
 2. Furnish a copy of the records of inspection, as well as the records of corrective action taken to Engineer.

Maintenance & Monitoring

The following maintenance and monitoring recommendations come from the research report titled Assessment and Recommendations for the Operation of Standard Sumps as Best Practices for Stormwater Treatment (Volume 2) by Kurtis McIntire, Adam Howard, Omid Mohseni and John Gulliver, published May 2012, available at:

www.cts.umn.edu/Publications/.../pdfdownload.pl?id=1722

Excerpt begins:

As with any stormwater treatment device, the SAFL Baffle must be maintained.

Visual Inspection

After installing the SAFL Baffle into a sump manhole, the system should be visually inspected three times per year for the first two years. During this inspection, it is important to determine whether or not the SAFL Baffle is physically compromised, the sediment depth in the sump, and remove any debris from the sump.

Additionally, the sediment captured at the bottom of the sump should be measured. This can be done by using a stick ruler with a point that can penetrate the sediment and reach the concrete bottom of the sump, and a stick ruler with a flat disk that will stop when reaching the sediment. The difference in distance measurements between these rulers is the depth of sediment in the sump. Several measurements should be taken to determine an average sediment depth in the sump, because the sediment bed will not be perfectly flat.

When visually inspecting the SAFL Baffle, it is important to check for clogging due to debris like trash and vegetation. Debris clogging the SAFL Baffle can cause washout in shallow sumps. Any debris stuck in the sump upstream of the SAFL Baffle should be removed. Afterwards, debris stuck on the SAFL Baffle should be removed.

Visual Inspection Checklist:

1. Previous Inspection - Has this SAFL Baffle been inspected before? If so, when?
2. Rainfall - Has it rained recently? If so, when? How many inches?
3. Access - Is the sump manhole accessible? If not, why?
4. Pipes - How many pipes connect to the sump?
5. Flow - How does water flow through the sump?
6. Debris - Is trash or vegetation in the sump? If so, what types of trash or vegetation are present?
7. Structural Integrity - Is the SAFL Baffle broken? Is it rusting? Are there pieces of the baffle that have become dislodged? Do any parts of the SAFL appear weak or damaged?
8. Clogging - Is anything clogging the baffle? If so, what is causing the clogging?

Sump Cleaning

Sump cleaning needs to take place to ensure maximum capture of sediment from stormwater. If sediment in the sump is not removed, sediment will accumulate at the bottom of the sump,

causing the sediment bed to rise towards the bottom of the SAFL Baffle. In turn, washout can occur during storm events.

Cleaning should be done with a truck mounted vacuum. If the manhole's casting and SAFL Baffle is designed properly, the SAFL Baffle should not get in the way of the truck's vacuum. Once the sediment and debris is removed from the sump, it can be disposed.

Excerpt ends

Nonstandard Designs

The SAFL Baffle can be used in a wide variety of situations, but was laboratory tested in a limited number of configurations. Sediment capture of sump structures with SAFL Baffle designs that deviate from the recommendations of this document cannot be accurately determined.

If unsure of your design, an engineer at Upstream Technologies will be glad to help. Please give us a call at 651-237-5123.

Sump Structures with less than 3-ft of depth

- You can install a SAFL Baffle, but it will not capture as much sediment as deeper sump manholes and it will need to be cleaned more frequently

Curb to sump structure

- The goal here is to get water traveling into the sump at a roughly horizontal direction. This can be done by altering local drainage (see image below) or by installing a curb inlet grate that routes water to a horizontal vector.
- Place the manhole behind the curb instead of below it, and extend a pipe from the curb inlet to the manhole. Use a curb inlet casting such as R-3262 or R-3268 from Neenah Foundry that directs water into a pipe behind the curb. These castings can be found here:

<http://www.nfco.com/municipal/products/curb-opening/>

